



# Flex separation systems, S separators 921–987

## Cleaning systems for heavy fuel oils\*



Flex system components for S separators 921–987.

\* S separators can also be used to clean lighter fuel oils and lubricating oils.

### S and P Flex separation systems

Alfa Laval's S and P Flex separation systems combine the high efficiency, low sludge output and low operating cost of Alfa Laval centrifugal separators with a flexible scope of supply. Extensive possibilities for the separation system layout and assembly make it possible to suit any engine room and any oil separation application.

In addition, S and P Flex separation systems feature the EPC 60 controller, which enables the intuitive navigation of menus, parameters and alarms. The EPC 60 controller also has a modular construction for easy I/O board addition and replacement.

The S and P Flex separation concept includes the complete S- and P-separator range. These can be combined in mixed ship sets, even within a single customer-specified module.

### Application S separators

S separators are based on Alcap technology, which means they automatically adjust the oil/water interphase based on the water content in the clean oil outlet. This makes them particularly suitable for separating heavy fuel oils with varying density, though they can be used to clean all of the following:

- Heavy fuel oils with densities up to 1 010 kg/m<sup>3</sup> and viscosities up to 700 cSt/50°C (higher viscosities available upon request)
- Lubricating oils
- Distillates
- Lighter diesel oils

S separators are designed for automatic operation in periodically unmanned engine rooms at sea and in automated power stations ashore.

**Scope of supply**

The S and P Flex separation concept provides a wide range of alternatives for S separators. Depending on the need, a S separator can be supplied as a separator and ancillaries, as a customer-specified module, or as part of a comprehensive package including services and order-specific documentation. These S separators come equipped with energy-efficient IE3 motors.

**Flex system**

A S separator with ancillaries in the form of optimized block components provides full say over the use of space. This allows for local modularization or do-it-yourself assembly.

**Flex modules**

A compact S separator module can be built to a customer-specified configuration from a wide range of modular skids and machine blocks. Multi-modules are possible, as well as mixed modules including one or more S separators and/or P-separators for the simultaneous treatment of different types of mineral oils. All Flex modules are factory tested to ensure faster start-up and commissioning.

**Features and benefits**

- *Small footprint, high flexibility*  
The small separator and the modular nature of the surrounding components allow easy installation and flexible positioning in the engine room.
- *Alcap technology*  
A water transducer in the clean oil outlet automatically adjusts the oil/water interphase to maximize separation performance.
- *High separation efficiency*  
An optimized design ensures the best possible separation efficiency from the bowl and disc stack.
- *CentriShoot*  
The CentriShoot discharge system greatly reduces sludge volumes. Its fixed discharge slide flexes gently to expose the discharge ports, thereby eliminating metal-to-metal wear.
- *CentriLock*  
The CentriLock bowl-locking system uses a lightweight, non-threaded snap ring. This prevents wear by allowing easy removal without a sledgehammer.
- *Long service intervals*  
Wear-preventing features like CentriShoot and CentriLock reduce the consumption of spare parts and allow planned maintenance to be performed less often. This reduces operating costs.

**Module examples**



**Single Flex module**  
with separator (excluding heater and pump)



**Single Flex module**  
with separator, heater and pump

**Quadruple Flex module**  
with separators, heaters and pumps



- *Easy operation and service*  
The PLC based EPC 60 controller is designed for “one-button” starts and stops, as well as intuitive menu navigation. Information about parameters and alarms can be easily accessed, which simplifies both operation and troubleshooting. The EPC 60 also has a modular construction that enables faster troubleshooting and I/O board replacement.
- *Remote control and monitoring*  
Using Ethernet or Bus communication, Flex systems and modules based on S separators 921–987 can be operated and supervised remotely from the control room. A variety of alarm functions are available as standard, and extra I/O boards can be added to the EPC 60 controller in order to enhance its operating and monitoring capabilities.

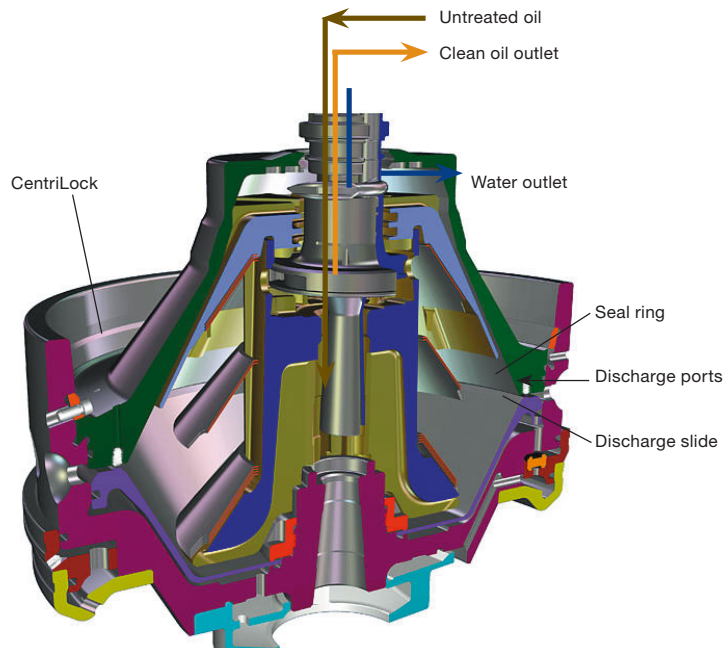

### Optional equipment

Flex separation systems based on S separators 921–987 can be complemented with the following equipment:

- Starter (included in module versions)
- HEATPAC heaters
- Space heating
- Additional thermometers
- Vibration sensor kit
- ALP feed pump
- Flow regulating system
- Sludge removal kit
- Sludge outlet butterfly valve kit
- Steam shut-off valve kit
- Air pressure reducer valve
- Pipe arrangement for multiple modules, including heater cross-connection
- Emergency safety shutdown
- Remote monitoring and control
- Separator lifting tool



ALP feed pump



HEATPAC CBM heater



HEATPAC EHM heater

### Schematic diagram

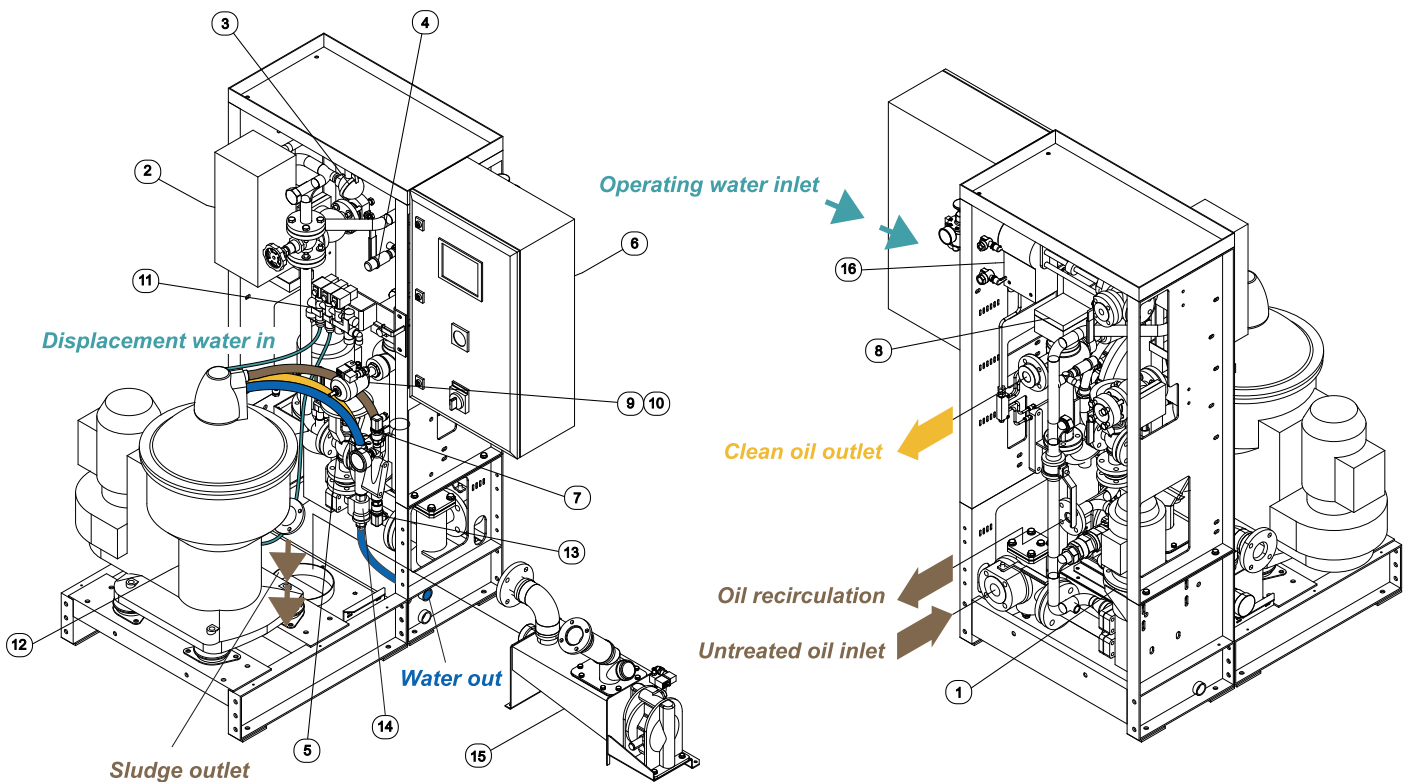

- |                           |                              |                             |                                 |
|---------------------------|------------------------------|-----------------------------|---------------------------------|
| 1 Feed pump               | 5 Change-over valve          | 9 Regulating valve – oil    | 13 Pressure transmitter – water |
| 2 Heater                  | 6 Process controller         | 10 Pneumatic shut-off valve | 14 Drain valve                  |
| 3 Temperature transmitter | 7 Pressure transmitter – oil | 11 Valve block water        | 15 Sludge removal kit           |
| 4 Safety valve            | 8 Complete regulating valve  | 12 Separator                | 16 Regulating valve             |

## System layout

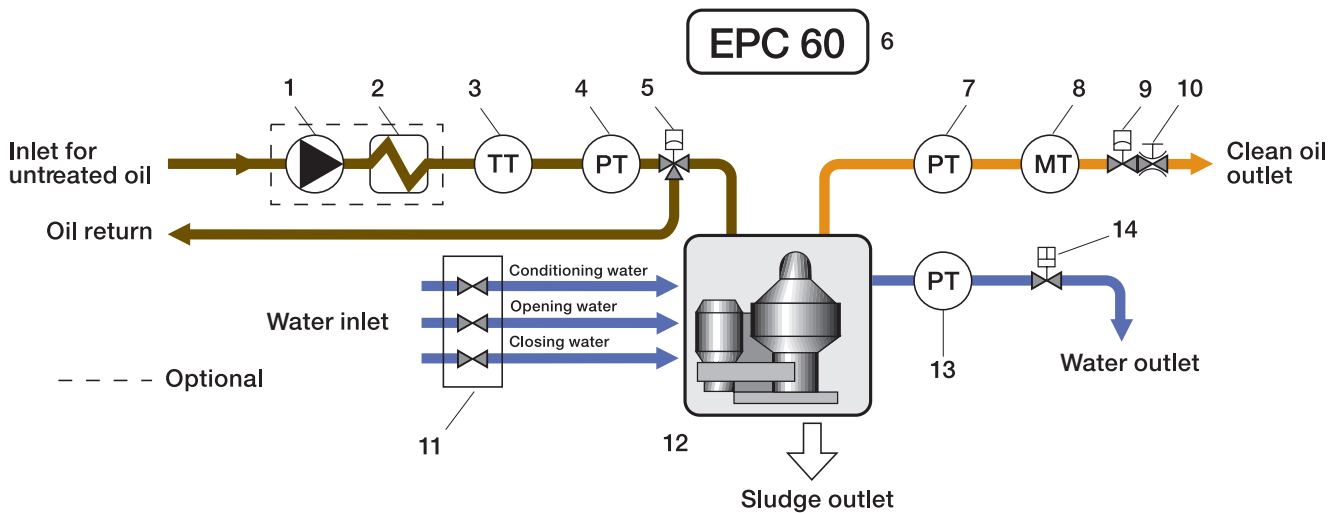

- |   |  |                                 |
|---|--|---------------------------------|
| 1. Feed pump                                  | 6. Control unit                            | 11. Solenoid valve block, water |
| 2. Heater                                     | 7. Pressure transmitter, oil               | 12. Separator                   |
| 3. Temperature transmitter                    | 8. Water transducer                        | 13. Pressure transmitter, water |
| 4. Pressure transmitter, oil                  | 9. Pneumatically controlled shut-off valve | 14. Drain valve                 |
| 5. Pneumatically controlled change-over valve | 10. Regulating valve                       |                                 |

## Operating principle

A Flex separation system based on an S separator 921–987 is operated automatically by the EPC 60 controller. Untreated oil, heated to the correct temperature, is fed continuously to the separator, which is driven by an electric motor via a friction clutch and belt.

The separator bowl is fixed at the top of a spindle, which is supported by bearings and special composite springs. During operation, separated sludge and water accumulate at the bowl periphery and are intermittently discharged by the high-precision CentriShoot discharge system.

The separator's operation is based on the Alcap principle, which means the separator automatically adjusts to the nature of the oil. No gravity disc is needed. A water transducer in the clean oil outlet measures capacitive resistance and signals changes to the EPC 60 controller.

Depending on the water content, the EPC 60 either opens the drain valve or expels the water through the bowl discharge ports during sludge discharge. A patented paring tube adapts itself to remove the water from the bowl while a paring disc pumps away the clean oil.

During normal operation, vital process parameters are monitored. These parameters, as well as alarms, are indicated by easy-to-understand text messages on the LCD display of the EPC 60 controller.

The EPC 60 controller provides many alarm functions, including alarms for low oil pressure, high sludge tank level (if the optional sludge removal kit is included) and power failure. Additional functions are available for a vibration alarm when the optional vibration sensor is fitted.

### Low-wear mechanical platform

S separators 921–987 and P separators 626/636 are built on a low-wear mechanical platform that features CentriShoot and CentriLock. The CentriShoot discharge system, which greatly reduces sludge volumes, has a fixed discharge slide that flexes gently to expose the discharge ports, thereby eliminating metal-to-metal wear. The CentriLock bowl-locking system uses a lightweight, non-threaded snap ring that prevents wear by allowing easy removal without a sledgehammer.



### CentriShoot

Instead of a sliding bowl bottom, the CentriShoot discharge system features a fixed discharge slide that flexes at its edge. This increases discharge accuracy and does away with metal-to-metal wear.

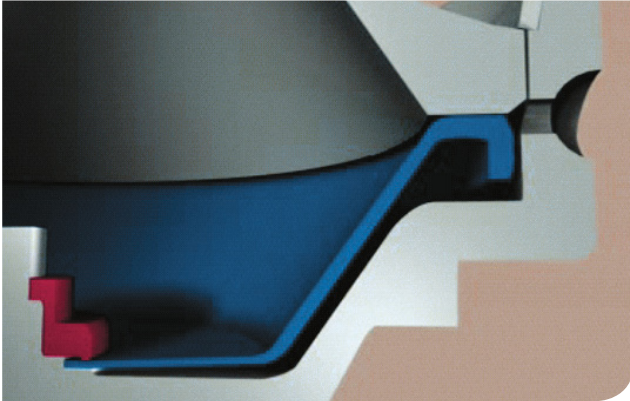

**Step one:**  
The CentriShoot discharge slide is fixed at the centre. During separation, the slide covers the discharge ports.

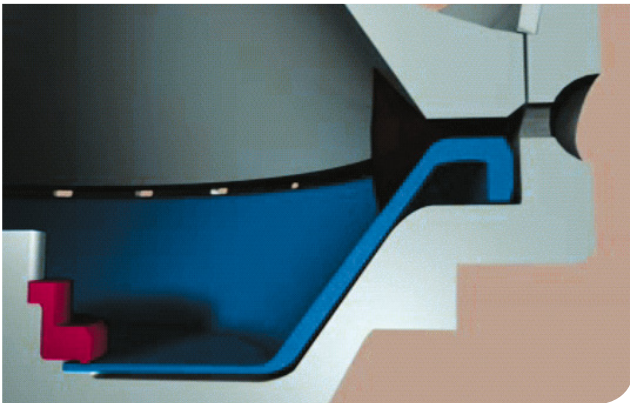

**Step two:**  
During sludge discharge, the edge of the slide flexes downward, exposing the discharge ports.

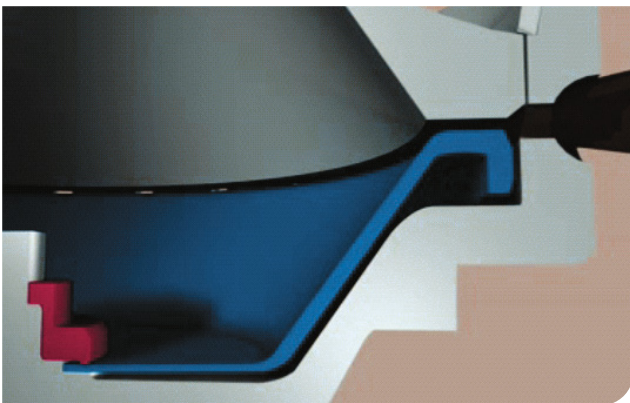

**Step three:**  
After discharge, the slide moves gently back into position to close the ports. This is done hydraulically, without any springs.

### CentriLock

Conventional lock rings are threaded and must be removed with a sledgehammer. Over time, the metal-to-metal wear between bowl and lock ring can lead to expensive bowl repair or replacement.



An Allen key is the only tool needed to work with CentriLock. No sledgehammer is necessary.



The CentriLock snap ring lifts out and snaps in easily – without any threads to wear.

Instead of a conventional lock ring, the CentriLock bowl-locking system features a non-threaded snap ring. This lightweight ring snaps quickly into place and is easily removed with only an Allen key.

## Operations

Preventive maintenance procedures are handled quickly and simply with the help of a compression tool. The snap ring of the patented CentriLock bowl-locking system is non-threaded and requires only an Allen key to remove.

- Maintenance intervals:
  - Inspection Service every 4 000 h or 6 months
  - Overhaul Service every 12 000 h or 18 months
- Service spares kits contain all necessary spare parts for each service and tips for maintenance in checkpoints:
  - Inspection Kit with O-rings and seals for separator bowl
  - Overhaul Kit with parts for drive system, belt, bearings and pads, also containing an Inspection Kit
  - Support Kit with strategic spares for operation and maintenance backup
- The System Manual includes detailed information in electronic or printed form:
  - Installation instructions
  - Operating instructions
  - Alarms and troubleshooting
  - Service and spare parts
- Commissioning and technical services are available from all Alfa Laval offices, including start-up assistance and advice on operation and maintenance.
- Training in all aspects of oil treatment, freshwater generation and heat transfer is available.
- All services can be incorporated into specially tailored Nonstop Performance packages. Details are available from local Alfa Laval offices.

## Max. recommended capacity, l/h HFO 380 cSt/50°C

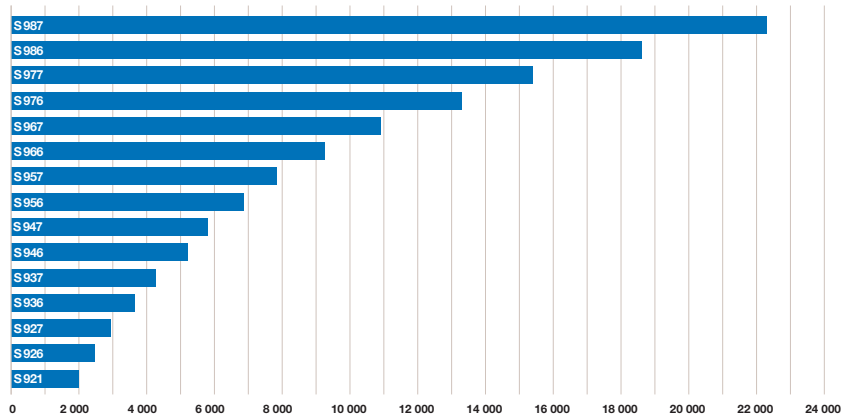

### Technical data

Main supply voltage	3-phase, 220 V up to 690 V
Control voltage	1-phase, 100/110/115/230 V
Frequency	50 or 60 Hz
Control air	Min 5 bar, max 8 bar
Operating water pressure	Min 2 bar, max 8 bar

Flex system	Size (height x width x length)*	Net weight (kg)
S 921/926/927	970 x 750 x 1075	426
S 936/937	1059 x 850 x 1195	500
S 946/947	1123 x 850 x 1195	626
S 956/957	1291 x 1000 x 1325	835
S 966/967	1405 x 1000 x 1325	984
S 976/977	1526 x 1250 x 1525	1281
S 986/987	1713 x 1250 x 1525	1793

\* Dimensions and weights for Flex systems do not include control cabinet.

Flex module	Size (height x width x length)**	Net weight (kg)
S 921/926/927	1750 x 750 x 1075	540
S 936/937	1750 x 850 x 1195	638
S 946/947	1750 x 850 x 1195	761
S 956/957	1766 x 1000 x 1325	1042
S 966/967	1766 x 1000 x 1325	1191
S 976/977	1766 x 1250 x 1525	1525
S 986/987	1766 x 1250 x 1525	2026

\*\* Dimensions and weights for Flex modules do not include pump and heater.



### How to contact Alfa Laval

Up-to-date Alfa Laval contact details for all countries are always available on our website at [www.alfalaval.com](http://www.alfalaval.com)